

Document Title: MAINTENANCE BULLETIN S-MN-GEN-7352			 Simpsonville, South Carolina	
Erema Incline Belt Conveyor Roller Modification v1				
Document Number: S-MN-GEN-7352	Rev No: 01	Date: 05/05/14	Document Owner: Reliability & CI Manager	Approvers: Maintenance Manager

1. SCOPE

- 1.1. This document describes and details the modification/s and requisite task/s instructions in original equipment manufacturer design in the SC1 Erema recycling machine incline belt conveyor deflection roller at the Fitesa, Simpsonville plant, SC.

2. DEFINITIONS

- 2.1. Deflection Roller the original equipment manufacturer's specific nomenclature for the incline feed conveyor end roller. For the purposes of this maintenance bulletin it will be referred to as *roller*.
- 2.2. OEM Original Equipment Manufacturer.
- 2.3. In situ in the original intended position or place
- 2.4. P-F Interval P-F Curve in reliability engineering this is the interval period between the potential occurrence of a failure and the decay into its functional failure
- 2.5. Fill-hole for the purpose of this document the term 'fill-hole' refers to the M5 blind set screw hole that is has been drilled and counter tapped in both end covers by the OEM which serve as a point to install a M5 extraction device to remove the end covers on the roller of the deflection roller, but as part of this modification it also serves as an indication that the void between the end cover and the internal bearing is full with grease which is indicated by pumping grease via the grease zerk on the outside of the roller using a grease gun into the void. When the void is full with grease, grease will flow out from the M5 set screw hole telling the operator or maintenance technician that the void is full, hence 'fill-hole' the void is completely filled with grease.

3. AFFECTED AREA / MACHINE / EQUIPMENT / PRODUCT / COMPONENT / MATERIAL

- 3.1. SC1 Erema recycling machine 906 T. Commission number P09/193 / ENA 874.
- 3.1.1. Incline feed belt conveyor roller. This is the conveyor that feeds material from the VecoPlan into the cutter compactor.

4. FAULT ISOLATION CODE

- 4.1. N/A.

Doc ID:	S-MN-GEN-7352	Revision:	01	Date:	7/3/2014	Maintenance Bulletin S-MN-GEN-7352
						Page 1 of 24

5. AFFECTED DATES RANGE

5.1. 07/01/2014 – Indefinite.

6. COMMUNICATION

6.1. Communication of this Maintenance Bulletin shall be made known to affected parties by electronic mail and internal customer maintenance review meetings maintenance notice boards and training and by the process used in form S-MOC-QA-0012.

7. TRAINING

7.1. Change management training of this Maintenance Bulletin shall be made by the author to all affected staff by audio / visual aids and on the job as a single point lesson and trainee and trainer shall fill out and sign completion record of the afore.

8. BACKGROUND DIAGNOSTICS / FACTORS / CAUSAL FACTORS / CAUSES

8.1. From commission 01/08/2010 The Erema deflector roller has failed X 5 times. By definition failed means that the roller is unable to rotate. MTBF = 12 months The main reason is that the bearings for the roller have seized thus preventing the idler shaft of the roller to rotate freely. Servicing the bearings in the ends of the roller is difficult as the roller has to be completely removed from in situ, partially dismantled and then greased and re-assembled. Pics. 8.1.1. and 8.1.2.

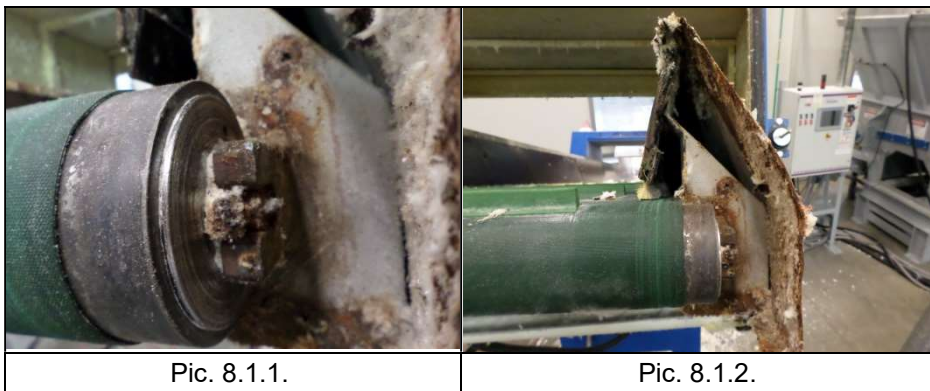

9. COUNTERMEASURES TAKEN – CHANGE PLANNING

9.1. Following a physical analysis it was determined that there was insufficient sealing of the end which allowed steam to enter the inside of the roller cavity contact the internally fitted spherical bearing enter the bearing and wash out the lubrication grease and leave the bearing unlubricated which accelerated it deterioration to the point of functional failure.

- 9.2.** Maintenance of the bearing is cumbersome as the whole conveyor must first be pulled back from the cutter compactor, the cleated incline conveyor belt loosened, the roller removed, the end covers removed and then the bearings greased. Then the unit needs to be re-assembled. Changes in the design of the roller and methods of greasing the bearing would be necessary to 1. Increase the mean time between failure of the roller bearings or at the very least increase the P-F interval from 1 month to 3 months. 2. Make the task of servicing the roller — greasing — bearings easier. How this is to be accomplished is detailed in this document.
- 9.3.** Picture 9.3. Demonstrates the arrangement of the roller in situ with the incline feed conveyor.
- 9.4.** It was determined by the author that modification to the OEM design of the roller was requisite in order to achieve a longer mean time between failure of the roller bearings and ease of maintenance access to achieve the afore. **Note:** In making this decision and the subsequent conceptions of re-design it is always has to be balanced with a ratio of action / effort to impact / effect. Completely re-designing the the roller and the end of the incline feed conveyor would be uneconomical. Making countermeasures that satisfies what is 'acceptable' and/or 'tolerable' to the organization without incurring un-recoupable financial impacts and having neither negative safety impacts nor negative environmental impacts is the imperative.

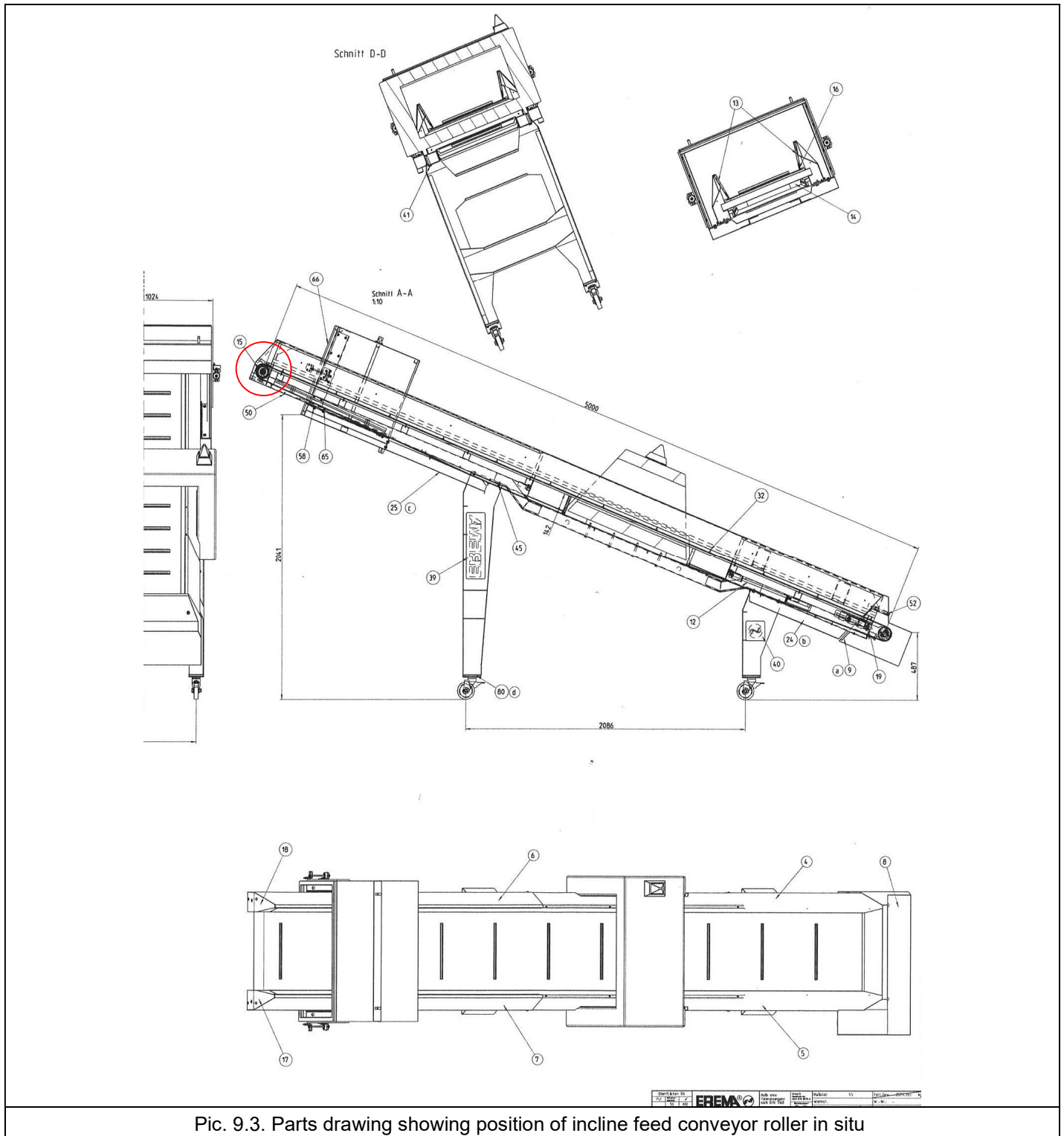

Pic. 9.3. Parts drawing showing position of incline feed conveyor roller in situ

9.5. Picture 9.5. showing the original equipment manufacturer bearing installation method.

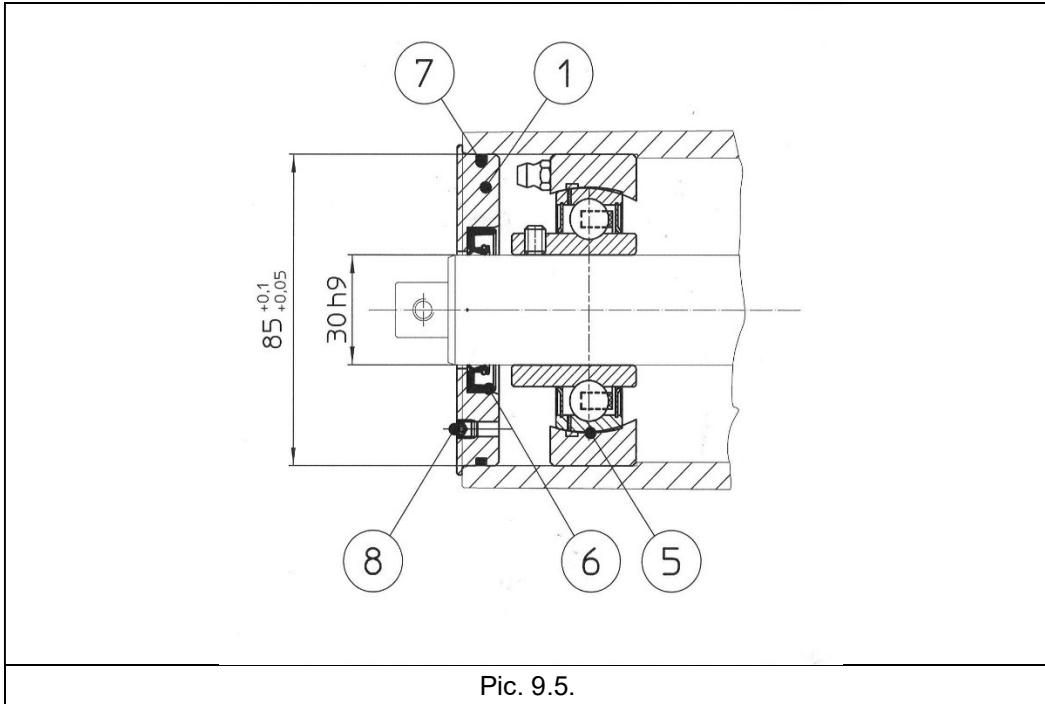

Pic. 9.5.

9.6. Picture 9.6. showing the modifications to the roller

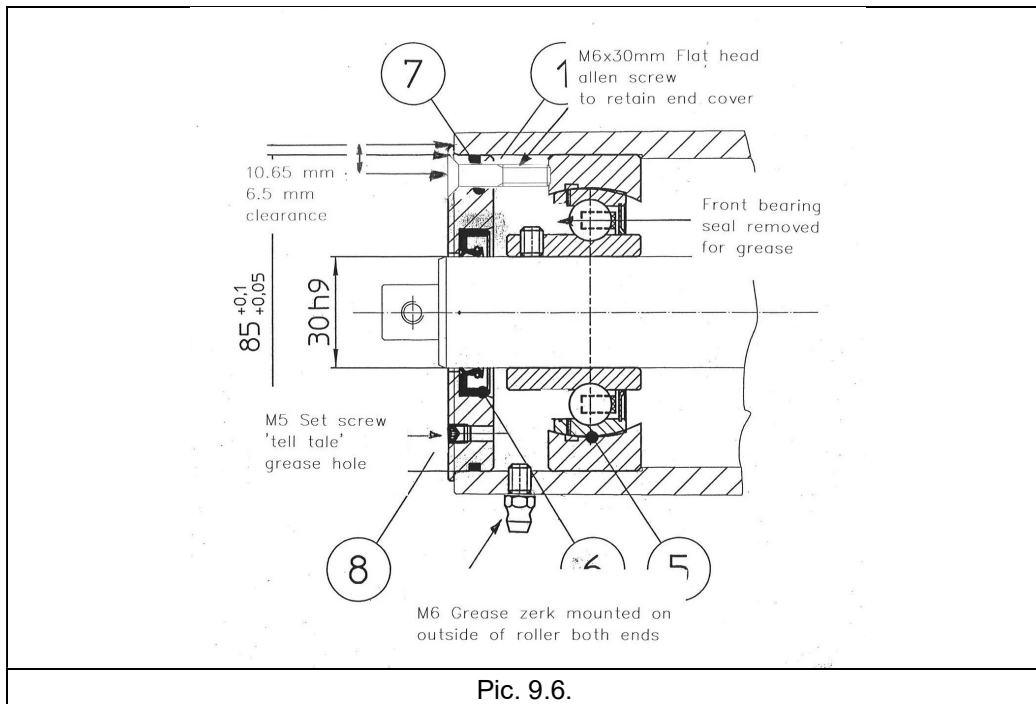

Pic. 9.6.

9.7. The modifications to the roller and end covers included the drilling and counter-sinking a 6.5 mm clearance hole aligning with the M6 grease access port to the spherical bearing housing Pic. 9.7.1.. This was to retain the end cover to prevent it from being pushed out

during greasing – detailed below. The other modification was to remove the front bearing seal and then fill the area inside the end of the roller with grease.

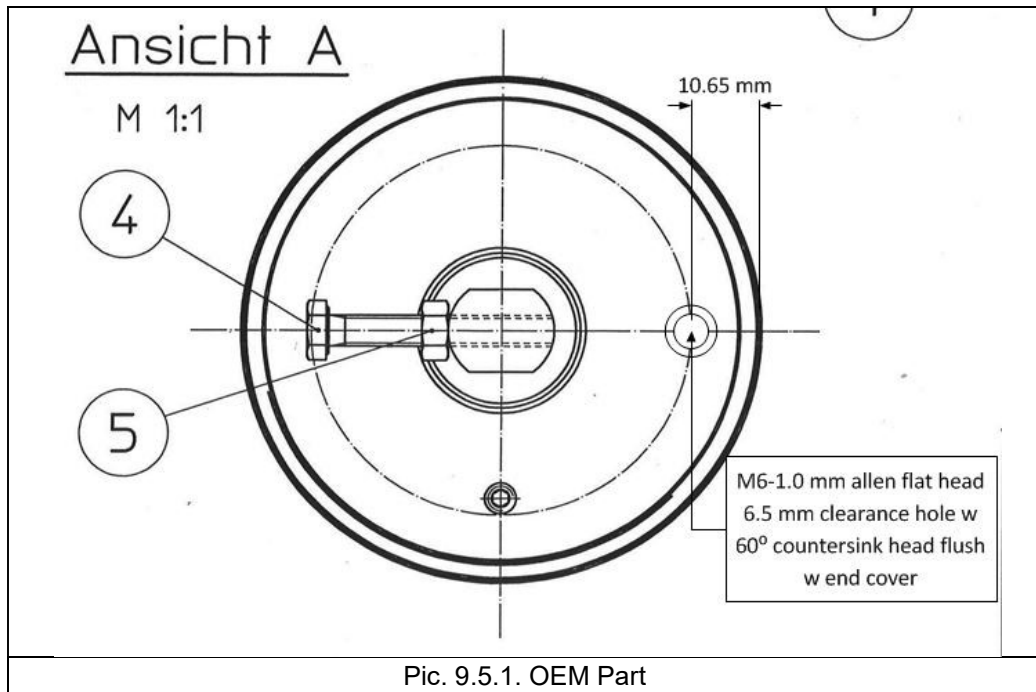

10. TESTING AND VALIDATION / PFMEA / PPAD / LOT TRACEABILITY / PROCESS FLOW DIAGRAM

- 10.1. The modified part has been manufactured from the pattern of the original equipment manufacturers same grade and composition of materials. The modified end cover was installed and monitored for fit, form and function and its performance is satisfactory.
- 10.2. PFMEA – Author conducted.
- 10.3. PPAD – not required. Change will not impact the end customers. Change will not affect the product predetermined specifications and quality attributes.
- 10.4. Lot Traceability – not required.
- 10.5. Process Flow Diagram – not required.
- 10.6. Temporary Change Notice – Not required see. 10.3.
- 10.7. Required Documents Update.

10.7.1. See 11.1.1. Change management forms to be completed.

10.8. Required Forms Change.

10.8.1. MOC Form S-MOC-QA-0012 location and access - SoftExpert.

11. REFERENCES

11.1. Documentation

11.1.1. Applicable changes in nomenclature and technical drawings have been made in the OEM Erema equipment manual Erema Mechanical Drawings, part list 1 / page 1/1 items 1, Cover, 5, Cast-bearing unit drg.no/mod.index 103730/0 title block references this maintenance bulletin number.

11.2. Forms

11.2.1. S-AD-HR-8104 Training Attendance Record.

11.2.2. MOC Form S-MOC-QA-0012 location and access - SoftExpert

11.3. Responsibility

11.3.1. Authorized Fitesa Maintenance Technicians, Maintenance Repairs & Operations Coordinator trained in this work task procedure.

11.4. Frequency

11.4.1. When required replacement by the Maintenance Technician and when required reordering by the Maintenance Repairs and Operations Coordinator.

11.5. Materials

11.5.1. X 1, 18" 250 fine grit sandpaper.

11.5.2. X 1, box of available cotton rags.

11.5.3. X 1, M5 X 50 mm Allen cap bolt.

11.5.4. X 1, M5 fender washer.

11.5.5. X 1, 32 oz. of Green Grease No. 2 grease gun on grease gun pegboard labeled GREEN GREASE NO. 2 FOR USE ON EREMA DEFLECTION ROLLER.

11.5.6. X 1, 50 ml bottle of Loctite 620 high temperature high viscosity retaining compound for loose fitting and slip-fit assemblies.

11.5.7. X 1, 50 ml bottle of Loctite 243 thread locker.

11.5.8. X 2, Scotchbrite pads.

11.5.9. X 1, container of isopropyl alcohol.

11.6. Tools

11.6.1. X 2, 11 mm combination wrenches.

11.6.2. X 1, 4 mm Allen wrench.

11.6.3. X 1, 2.5 mm Allen short arm wrench Note: if a short arm Allen wrench is not available you can cut down the arm of an extra wrench using a die grinder so that the arm is approximately 35 mm long.

11.6.4. X 1, 5 mm Allen wrench.

11.6.5. X 1, 6 mm wrench Allen wrench.

11.6.6. X 1, 8 mm Allen wrench.

11.6.7. X 1, 7 mm ¼" drive socket.

11.6.8. X 1, ¼" drive socket screwdriver.

11.6.9. X 1, 6" long flat blade screwdriver.

11.6.10. X 1, 10" long flat blade screwdriver.

11.6.11. X 1, piece of ½" X ½" wood used to push rags through roller to clean out grease.

11.6.12. X 1, piece of 1" wide X 8-10" long X 1/8" thick aluminum – with the one of the ends shaped end to a chisel edge.

11.6.13. 2" Brass scraper.

11.6.14. X 1, 1 lb. ball peen hammer.

11.6.15. X 1, 1 lbs. plastic mallet.

11.6.16. X 1, 11.5 lbs. plastic mallet.

11.6.17. X 1, 5/8" ½ lb. side puller.

11.6.18. X 1, 1" Ø X 10-12" long aluminum drift or punch or round stock.

11.6.19. X 1, 1" Ø X 24" long aluminum drift or punch or round stock specially fashioned end to drift out bearing housing, kept in special hand tools in maintenance ship drawer marked SPECIAL HAND TOOLS.

11.6.20. X 1, 2" steel putty knife.

11.6.21. X 1, air blow gun.

11.6.22. X 1, 10" fine cut flat file.

11.6.23. X 1, 8' step ladder or the 12' platform ladder if available from Erema room.

11.7. Parts Requirements

11.7.1.1. X 2, OEM part reference number: Bearing 103730 Unit f conveyor Cover, bearing, seals, rings 103730 \ 10103730.

11.7.1.1.1. Fitesa part reference number: TBD.

11.8. HS&E Mandates / Concerns / Considerations

11.8.1. No health, safety or environmental mandates, concerns or consideration have been identified with this maintenance bulletin.

11.9. Personal Protective Equipment

11.9.1. Company mandated PPEs in designated areas.

11.9.2. X 1, Hasp clasp lockout/tagout lock per person actually working on the extruder unit attached to the Erema machine extruder.

- 11.9.3. X 1, Hasp clasp lockout/tagout lock per person actually working on the extruder to be attached to the Vecoplan machine.



WARNING: N/A

11.10. Guidelines

- 11.10.1. N/A.

12. ATTACHMENTS

- 12.1. N/A.

13. APPENDIX

- 13.1. N/A.

14. ACTIONS REQUIRED BY MAINTENANCE STAFF / LUBRICATION OF THE ROLLER BEARINGS

- 14.1. Shut down the machine in the proper procedure and apply lockout/tagout to all applicable power/control sources of energy.
- 14.2. Loosen and remove the rubber cone damper connector rod M8 nuts on both sides of the incline feed belt conveyor Pic. 14.2.1.

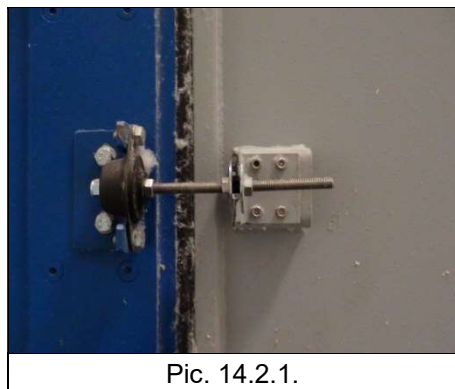

Pic. 14.2.1.

14.3. Unlock the conveyor caster wheels. Unclamp and unplug the electrical control socket plug Pic. 14.3.1. Push back the incline belt feed conveyor from the cutter compactor hood Pic. 14.3.2. Rotate to the left sufficiently that you are able to gain access to the top end of the conveyor Pic. 14.3.3.



14.4. If the grease zerk is not positioned as shown in Pic. 14.4.1. Plug the electrical control socket plug back in, remove lockout/tagout, restore power to the Erema machine and have someone turn on the incline conveyor while another person watches the belt and stop the belt when the grease zerk has rotated to the position as shown in Pic. 14.4.1. If restoring power is not possible you will have to rotate the roller manually. Remove the drive guard by removing the X 2 M8 cap head bolts Pic. 14.4.2. Remove the guard and set aside. Loosen the belt tensioner locking clamps on both sides of the conveyor Pics. 14.4.3 and 14.4.4. Loosen the belt tensioner/tracking adjusting nuts on both sides of the conveyor by about 1" Pics. 14.4.5. and 14.4.6. If necessary tap the ends of the belt tensioner/tracking brackets in using the 11.5 lbs plastic mallet. Pic. 14.4.7. This should provide you enough slack in the belt to allow you to rotate the roller to the position where you can access the grease zerk and 'fill-hole' Pic. 14.4.8.



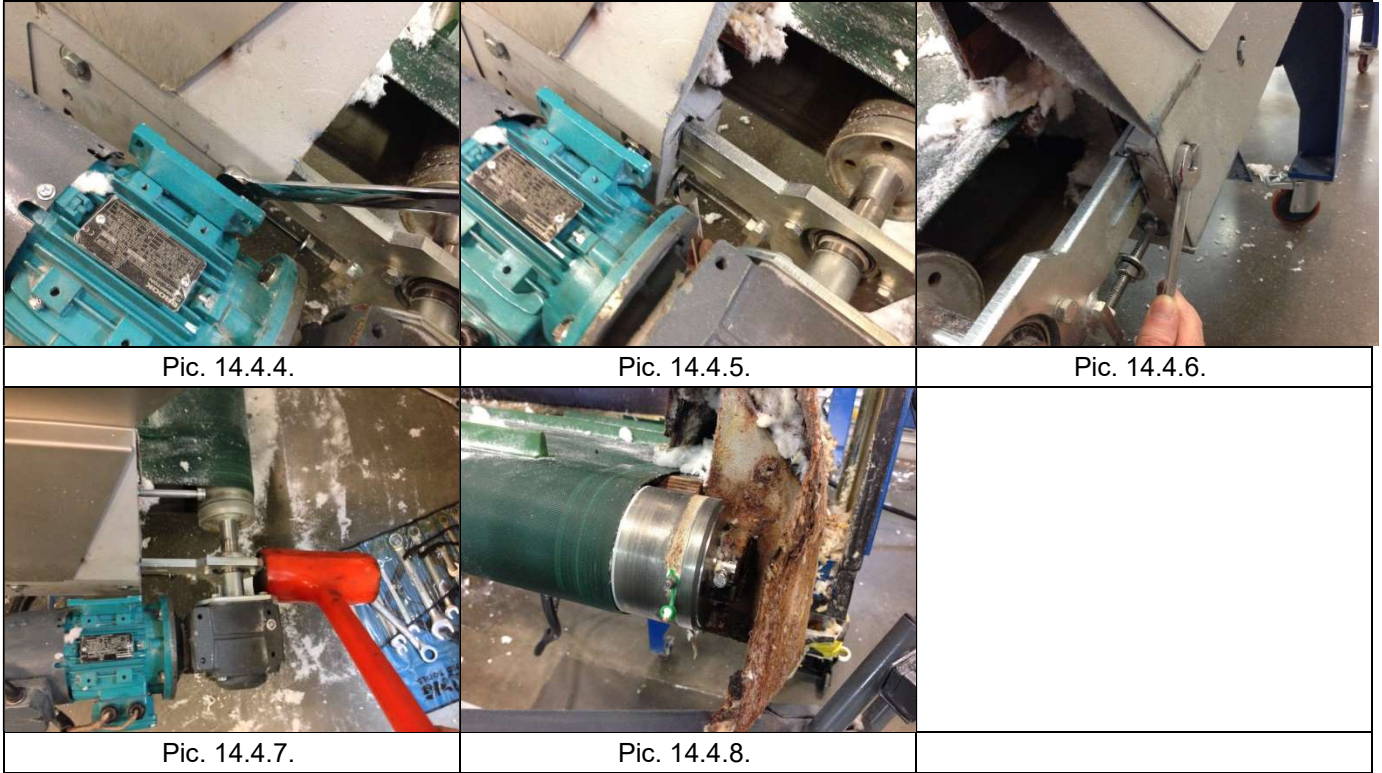

14.5. After using either method to rotate the roller to the desired position, re-apply lockout/tagout to all applicable power/control energy sources if conveyor was rotated by power on.

14.6. Position the 8' steps ladder or the 12' platform ladder if available from the Erema room next to the end of the conveyor Pic. 14.6.1. Using the 2.5 mm Allen wrench with the short arm loosen the M5 'fill-hole' screw and remove Pic. 14.6.2. Clean the grease zerk with a clean cotton rag Pic. 14.6.3. Install the grease gun nozzle and proceed to pump grease into the roller until it appears out of the 'fill-hole' Pic 14.6.4. Replace the M5 'fill-hole' screw and tighten Pic. 14.6.5. Re-attach the grease gun nozzle and give an additional 22 pumps of grease into the bearing Pic. 14.6.6. Repeat the same tasks for the other side of the roller bearing.

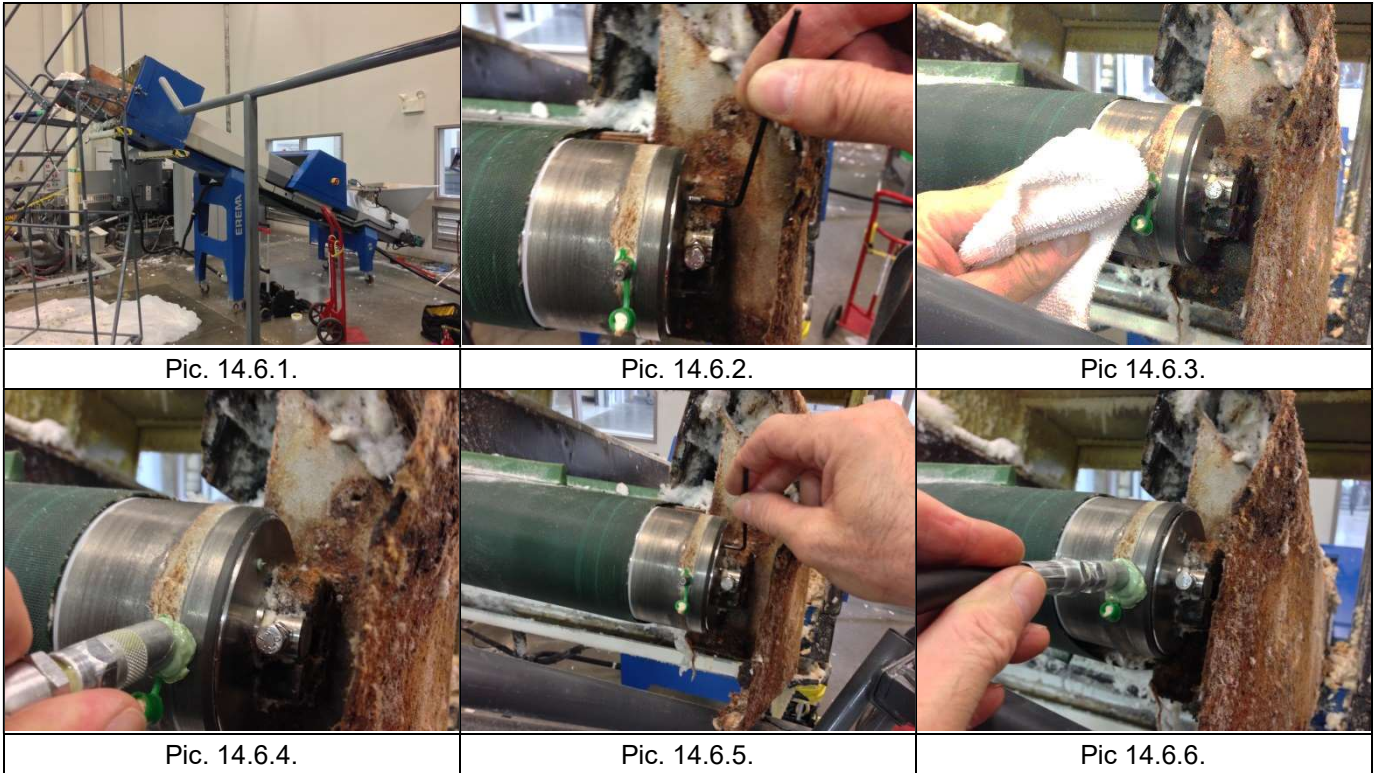

14.7. This completes the lubrication of the roller bearings.

14.8. Re-tension the conveyor belt to prepare to check for centered tracking of the belt. **Note:** There should be just enough tension on the belt to allow it to drive, but too much tension that will apply excessive loads all 4 bearings to the conveyor belt.

14.9. Restore power/control energy sources and turn on the incline feed conveyor belt.

14.10. Turn on incline conveyor belt and check for centered tracking of the belt. The belt should run centered on the roller. **Note:** Again, there should be just enough tension on the belt to allow it to drive, but too much tension that will apply excessive loads all 4 bearings to the conveyor belt this can cause accelerated failure of the bearings because of over tensioning and thus loading.

14.11. When tracking is complete stop the incline conveyor belt and re-apply lockout/tagout power/control energy sources and then re-install the drive guard cover.

14.12. Position the incline belt feed conveyor into the cutter compactor hood and secure in place with the rubber cone damper 8M nuts connector rods on both sides Pic. 14.2.1.

15. ACTIONS REQUIRED BY MAINTENANCE STAFF / ROLLER BEARINGS REPLACEMENT

- 15.1. Complete task instructions 14.1. through 14.3.
- 15.2. Remove the drive guard by removing the 2 M8 cap head bolts remove the guard and set aside. Loosen the belt tensioner locking clamps on both sides of the conveyor Pics. 14.4.3 and 14.4.4. Loosen the belt tensioner/tracking adjusting nuts on both sides of the conveyor by about 3" Pics. 14.4.5. and 14.4.6. If necessary tap the ends of the belt tensioner/tracking brackets in using the 11.5 lbs. plastic mallet. Pic. 14.4.6. This should provide you enough slack in the belt to allow you to remove the roller.
- 15.3. Pull enough slack in the belt to allow you pull the roller forward, over the location cleats and down under the conveyor and supported by the conveyor beat itself.
- 15.4. Slide the roller out through the underside of the conveyor.
- 15.5. Take the roller to the maintenance workshop.
- 15.6. Place the roller on the workbench.
- 15.7. Loosen the M6 shaft jack screw jamb nuts. Unscrew and remove the M6 shaft jack screws on both ends of the shaft Pic. 14.8.1.. Unscrew and remove the M6 X 30 mm Allen flat head cap screw Pic. 14.8.2.. Unscrew and remove the M5 set screw from the 'fill-hole' Pic. 14.8.3.



Pic. 14.8.1.



Pic. 14.3.2.

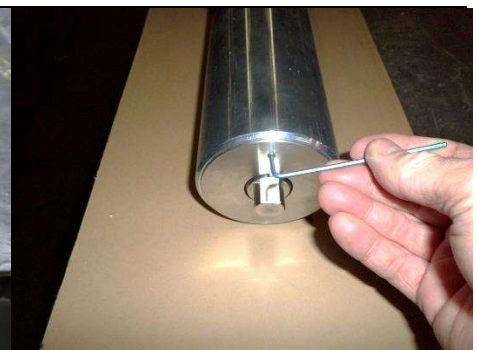

Pic 14.5.3.

- 15.8. Screw in the M5 X 50 mm Allen bolt with M5 fender washer into the M5 'fill-hole' hole Pic. 14.9.1. Align the side puller behind the head of the M5 fender washer and gently pull the the end cover just enough of a gap to allow you to use the 2" aluminum pry tool or a 2" brass scraper to get in behind the end cover Pic. 14.9.2. Using the 2" Aluminum pry tool or the 2' brass scraper carefully pry around the end cover to loosen it for removal Pic. 14.9.3. Repeat the same for the other end cover.



15.9. Remove the end covers Pic. 14.10.1. Using the cotton rags clean out all grease from the void area between the end cover and bearing Pic. 14.10.2. Using the 3 mm Allen wrench loosen the two bearing shaft locking set screws Pic. 14.10.3. Repeat the same for the other end of the roller.



15.10. Using the 1, 1" Ø X 10-12" long aluminum drift or punch or round stock align the tool with the end of the shaft and using the 1 lb. ball peen hammer drift out the shaft Pic. 14.11.1. Remove the shaft Pic. 14.11.2.. Using the 1" Ø X 24" long aluminum drift or punch or round stock insert it through the bearing inner race sleeve and side to down the hollow part of the roller until it butts up against the bearing housing of the other side of the roller Pic. 14.11.3.



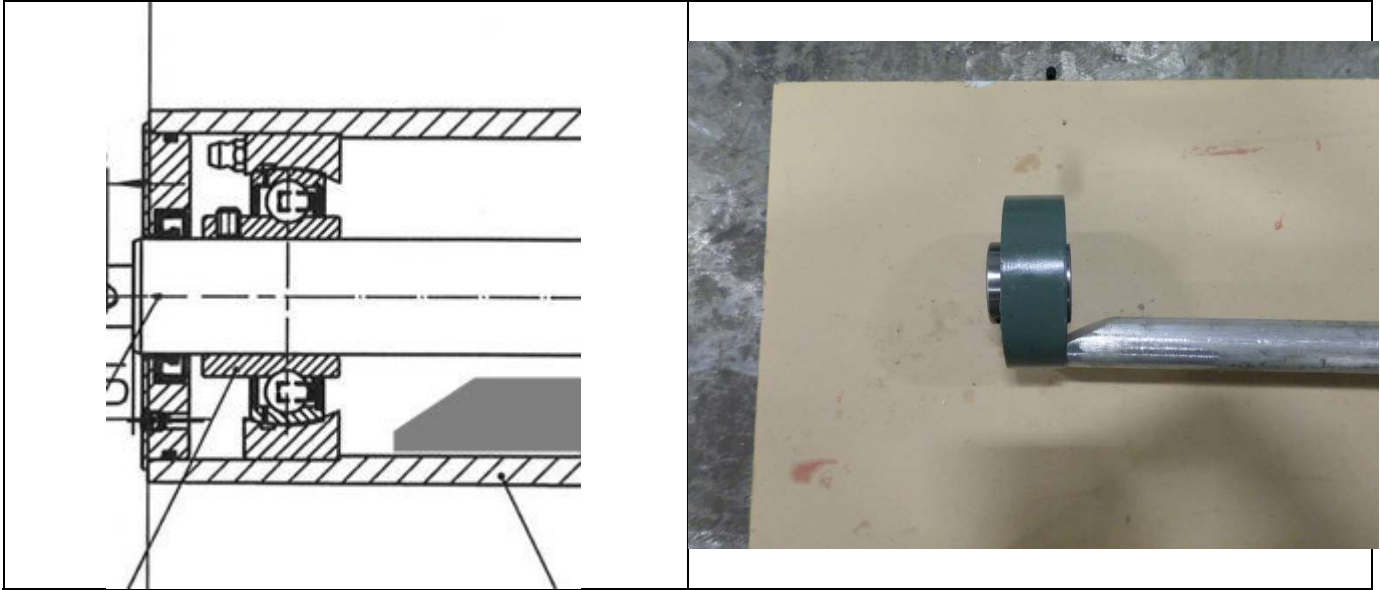

15.11. Proceed to slide the tool backwards and forwards against the bearing housing to drift the bearing housing out rotating the roller as you do so to make equal the force against the bearing housing Pics.14.12.1, 2 & 3.



15.12. Remove the bearing housing complete Pic. 14.13.1. Repeat the same for the other end of the roller. Using rags and the piece of ½" X ½" wood push any accumulated old grease in the hollow space between each end of the roller Pic. 14.13.2. Thoroughly clean the inside of the roller of grease and ends of the inside of the roller removing any residual retaining compound from the recesses of where the bearings were removed from their internal seats using the Scotchbrite pads if necessary Pic. 14.13.3.



15.13. Check the entire length of the shaft for score marks, dents or burrs and dress them as necessary using the 250 grit sandpaper Pic. 14.14.1. with severe dents or burrs dress with the fine 8" flat file Pic. 14.14.2. Inspect the o-rings for wear or damage replace if needed Pic. 14.13.3. Remove the o-rings from both end covers and clean the groove of both end covers Pic. 14.14.4. Inspect and clean shaft seals, replace if needed Pic. 14.14.5.

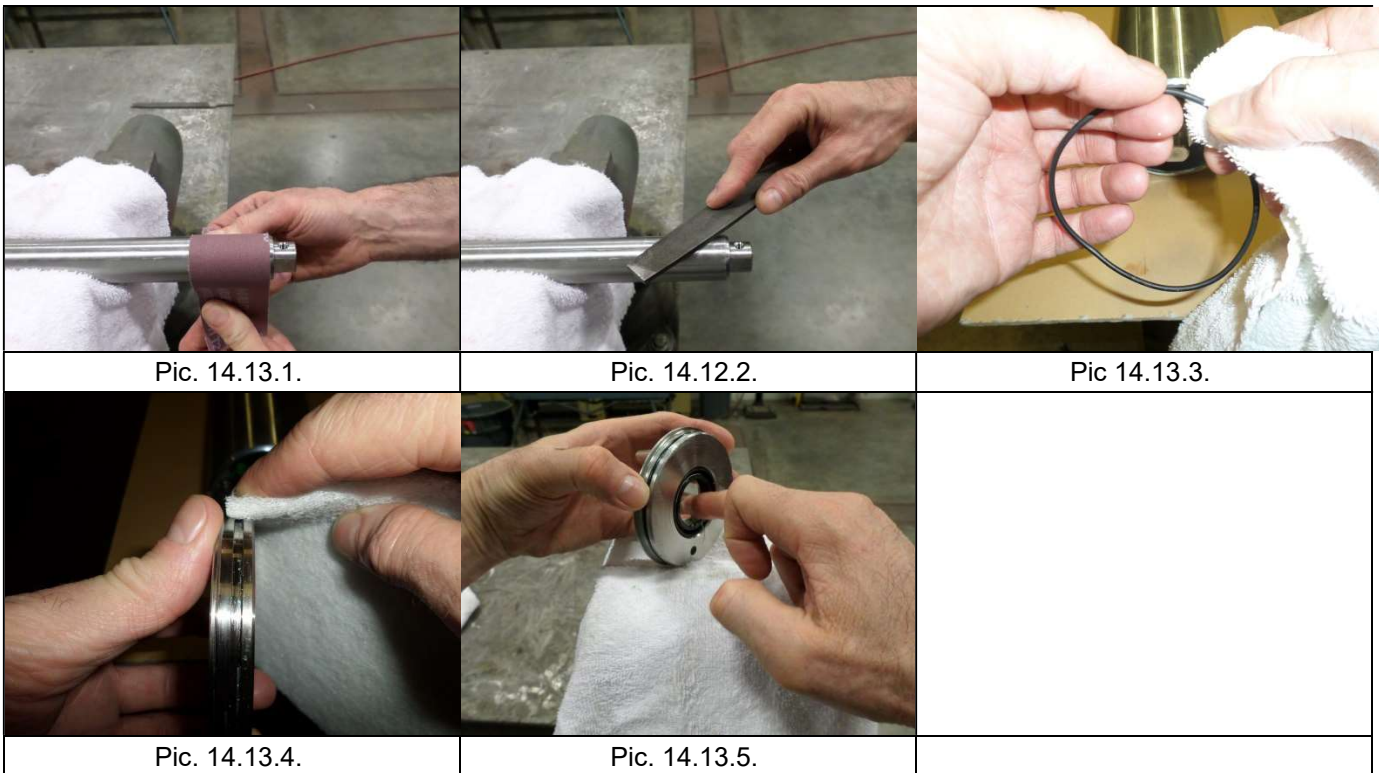

15.14. Unpack the new bearing and remove the grease zerk – if it is installed – using the 7 mm ¼" drive socket and ¼" drive screwdriver Pic.14.15.1. Using the 2" steel putty knife use the edge of the putty knife to get under the front seal retaining disc and remove the seal retaining disc Pic. 14.15.2.. Remove the front bearing seal Pic. 14.15.3.

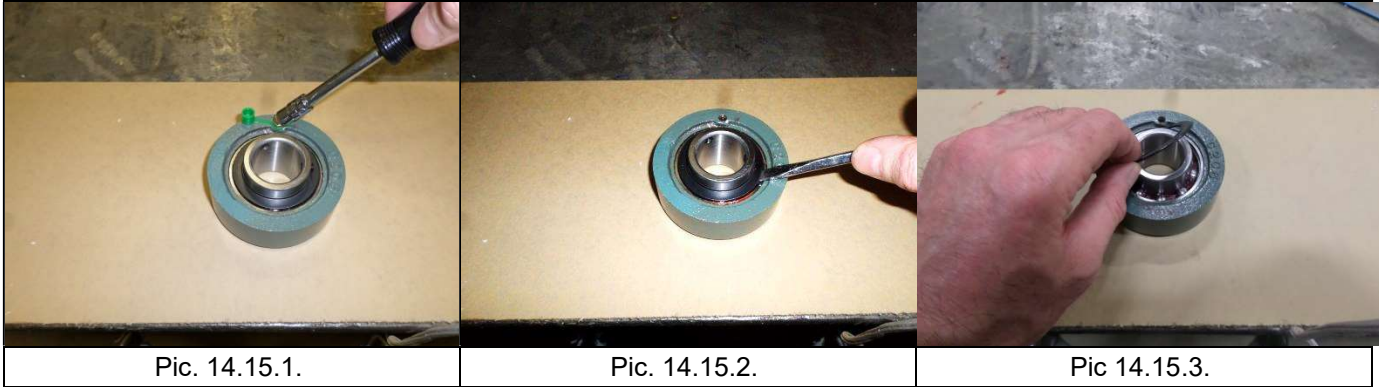

15.15. Using the air blow gun blow out all the pre-packed grease from the bearing and bearing housing grooves shielding the area around the bearing with a rag to prevent grease from being blown on your person and the work area Pic.14.16.1, 2, 3. Clean and degrease the M6 grease zerk threads with isopropyl alcohol.



15.16. For ease of the shaft installation it is important that the spherical bearing in the housing is square with its housing if not place the bearing housing in a lathe headstock chuck and bring the tailstock of the lathe up close to the bearing, lock it in place and bring the flush face of the tailstock up to the sleeve and the bearing until is to square Pic. 14.17.1, 2, & 3. – **DO NOT APPLY TOO MUCH FORCE**

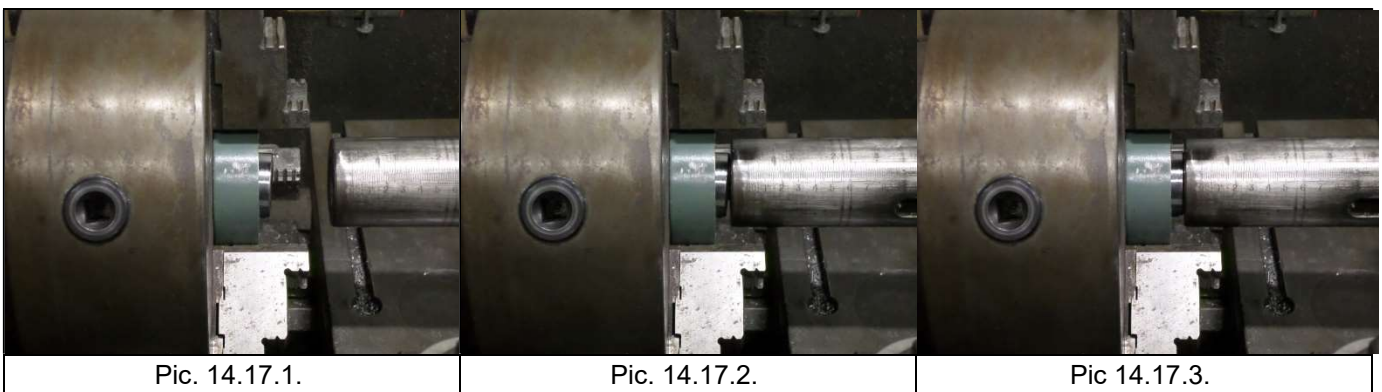

15.17. Thoroughly clean the bearing housing using a clean rag dipped isopropyl alcohol Pic. 14.18.1.. Thoroughly clean the inside ends of the roller with isopropyl alcohol and Scotchbrite pad if necessary Pic. 14.18.2. Thoroughly clean the the o-ring grooves of both end covers Pic. 14.18.3. Test to make sure the bearing fits and slides on the shaft by hand. **Note:** the bearing should fit on the shaft by hand, if it does not re-dress the shaft of burrs and the inner diameter of the bearing until the slides freely on the shaft.



Pic. 14.18.1.



Pic. 14.18.2.



Pic 14.17.3.

15.18. Apply a liberal amount of the Loctite 620 retaining compound to the peripheral surface the bearing housing Pic. 14.18.1.



Pic. 14.18.1.

15.19. Install the bearing in the inside end of the roller installing it so that the M6 tapped grease zerk thread on the bearing is 90° to 3 o'clock to the grease zerk on the roller Pic. 14.20.1. Apply a small amount of retaining compound to the outer surface of the bearing to inside roller to fill in any diametrical clearances. Wipe out any excess retaining compound. Repeat the same on the other side of the roller with the M6 tapped grease zerk thread on the bearing is 90° to the 9 o'clock to the grease zerk on the roller Pic. 14.20.3. **Note:** This to provide access to the grease zerk and 'fill-hole' for greasing the roller bearing in situ.

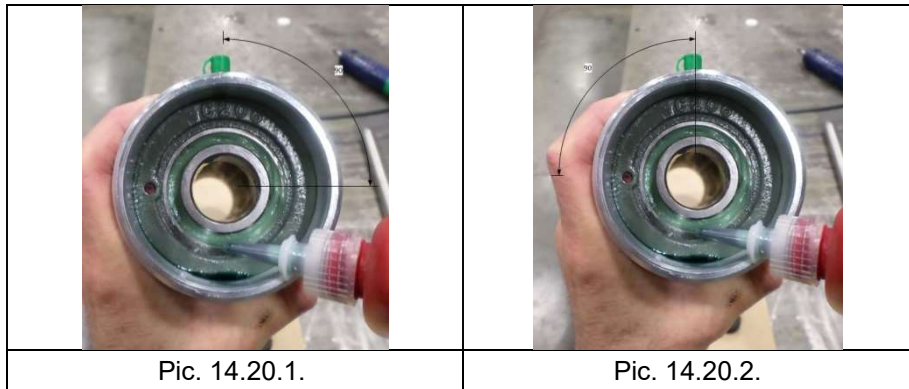

15.20. Leave the retaining compound to cure for 25 minutes.

15.21. Make sure the set screws in the bearings inner races sleeves are backed out from the inner diameter or they will prevent the shaft installation.

15.22. Place the roller on one of its ends on the floor Pic. 14.23.1. **Note:** Despite the picture it was found later by the author of this document that setting the end of the roller on the floor made the installation of the shaft easier. Apply a small amount of light-weight oil on the shaft end Pic. 14.23.2. Carefully align the shaft with the bearing inner race sleeve and pass the shaft down through the roller to the other bearing inner race sleeve and pass it through flush to the floor or workbench top surface Pic. 14.23.3.

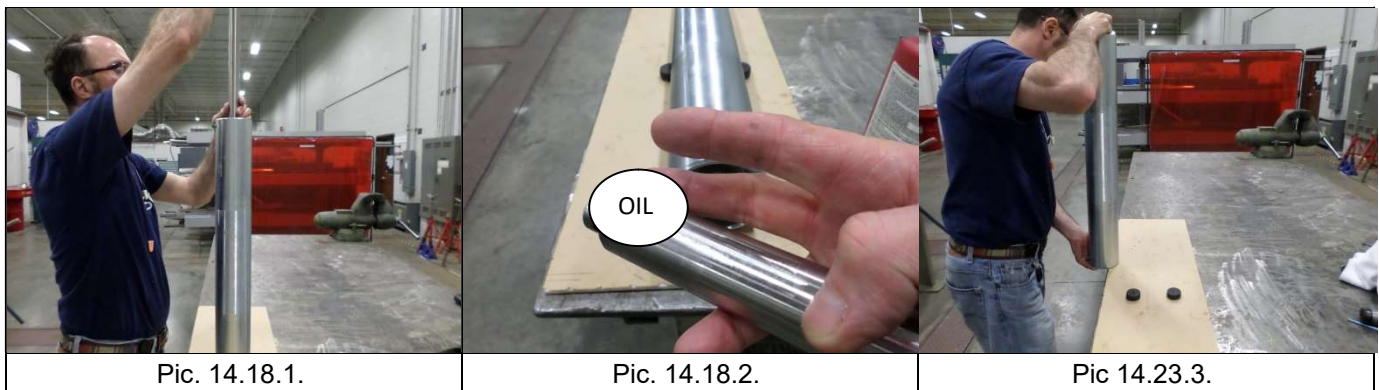

15.23. Lay the roller flat on the workbench top. Using the 1 lbs. plastic mallet gently tap the one end of the shaft until an equal amount of the shaft protrudes from each end of the roller as measured from the end of the shaft to the edge of the end of the roller = 19 mm Pic. 15.24.1 & 2.

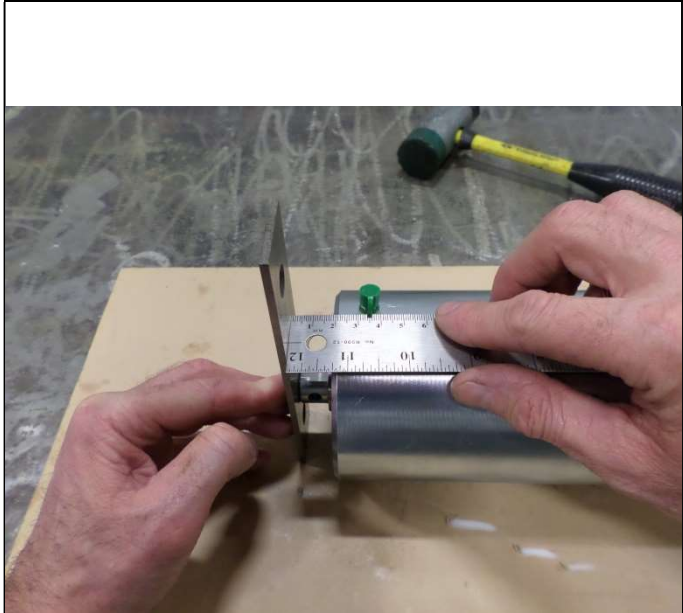

Pic. 15.24.1.

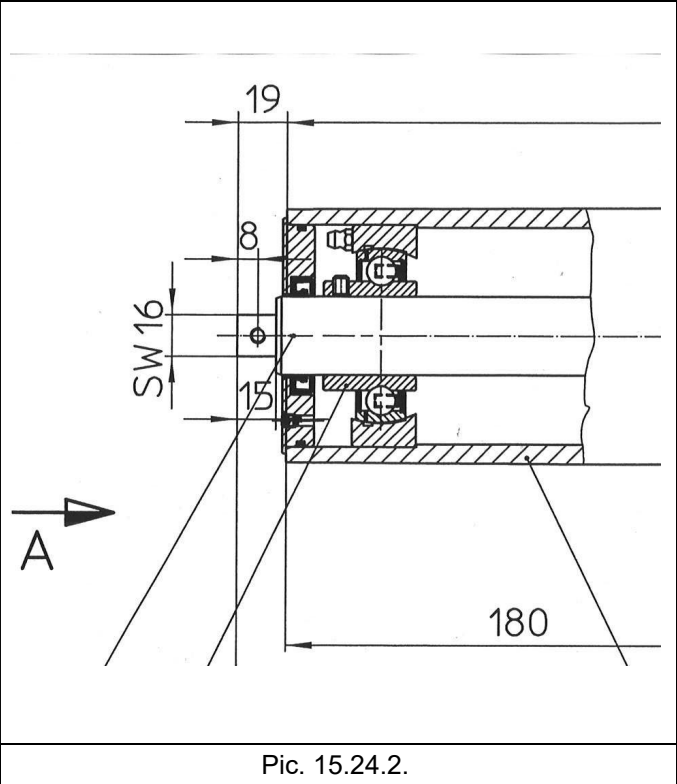

Pic. 15.24.2.

15.24. Once the correct dimension is achieved at both ends of the shaft tighten down the shaft locking set screws Pic. 15.25.1.



Pic. 15.25.1.

15.25. Install the o-rings back into the groove of the end covers Pic. 15.26.1. Apply a liberal amount of retaining compound around the o-ring and o-ring groove. Apply a small amount of Green Grease No 2 to the inner lips of the shaft seal Pic. 15.26.1. Align the M6 end cover screw hole with the M6 threaded part of the bearing housing and push the

end cover into the end of the roller Pic. 15.26.3. Apply Loctite 243 thread locker to the threads of the M6 X 30 mm Allen flat head screw install and tighten – **DO NOT OVERTIGHTEN**. Repeat the same on the other side of roller.



15.26. Remove the M5 'fill-hole' screw set from the end cover. Install the grease gun nozzle on the grease zerk Pic. 15.27.1. Proceed to give the grease gun 125 pumps of the grease gun pump trigger handle **Note:** 33 shot of grease equals 1 fl oz. It takes 4 fl oz to fill the void between the bearing housing and the inside of the roller end cover. When you see grease appear from the 'fill-hole' hole the void is full with grease. Re-install the M5 set screw. Re-attach the grease gun nozzle and proceed to give an additional 25 pumps of the grease gun trigger handle. **Note:** it takes .67 fl oz of grease to fill the bearing. Some grease will at this point and during subsequent servicing will be pushed into and out the of back seal of the bearing into the hollow space between the ends of the bearings in the roller. This is acceptable as fresh grease is pushed into the bearing the dirty grease is pushed into the hollow space and this will be clean during major overhauls - expected time of 2 years. Repeat the same for the other side of the roller.

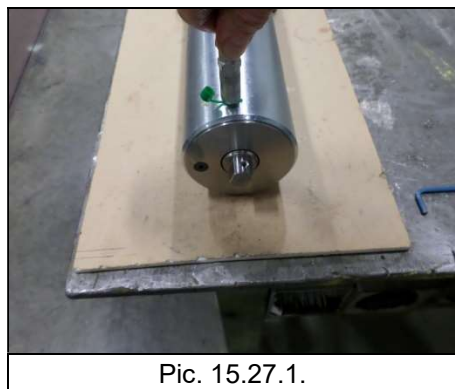

15.27. Re-install the M6 shaft jack screws Pic. 15.28.1. **Note:** Screw in the shaft jack screws so that 10 mm of thread protrudes out from the other end of the shaft. Lock the M6 shaft jack screw in place with the M6 jamb nut.



Pic. 15.28.1.

15.28. Take the roller back to the machine.

15.29. Lift the roller up and over the underside of the conveyor belt **Note:** Have someone assist you in this task.

15.30. Pull the roller forward and up over to the end of the conveyor to align the shaft end with the location cleats. Rotate the shaft of the roller until the flat of the shaft is aligned with location cleats and fit in place. **Note:** Make sure the hex head of the M6 shaft jack screw is facing outwards and the ends of both jack screws are nested in the location cleats Pic. 15.30.1.



Pic. 15.30.1.

15.31. Re-tension the belt and check for tracking as described in section 14.7. through 14.11.

15.32. This completes the roller bearings replacement.

16. ACTIONS REQUIRED BY MRO COORDINATOR

16.1. No special requirements needed by the MRO Coordinator, other than to stock and monitor the correct levels of spare parts for this task.

17. LONG TERM EFFECTIVENESS TRACKING

17.1. The author of this maintenance bulletin has conducted a PFMEA and no major long term effects have been identified with the change management.

18. RESPONSES / REACTION PLANS FROM ORIGINAL EQUIPMENT MANUFACTURER

18.1. The original equipment manufacturer was contacted in regard to this problem and their response was considered not congruent with the results of the physical analysis and data collected to the contrary by the author. The changes have been made notwithstanding any warranties in effect in sake of improved reliability resulting in an increase in the mean time between failure and reduction of unplanned downtime.

19. ATTACHMENT 1: N/A

--

20. ATTACHMENT 2: N/A

--

21. APPENDIX. N/A

Revision History:

Effective Date	Revision Number	Description of Change	Reason for Change
06/01/14	01	N/A	First Draft